



# PRODUCT SPECIFICATION

Model No: B0F-2016WD-DY15-60

For reference only.

Subject to change maybe necessary in a limited number of cases

## Descriptions:

- Ceramic Substrate Type
- SMD Chip Type
- Emitting Color : White
- Viewing Angle : 120°

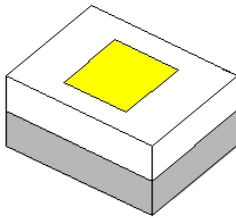

LED 胶体为软硅胶封装，请避免外力碰撞。

CUSTOMER APPROVED SIGNATURES	APPROVED BY	CHECKED BY	PREPARED BY
	Lin. yankai	Gao. yang9	Li. zhenzhen5

Address: Xiangshui River, Economic Development Zone, Daya Bay, Huizhou, Guangdong, 516083 P.R. China

地址: 广东省惠州市大亚湾响水河 (516083)

电话: +86-755-89888888; +86-752-5118888

Tel: +86-755-89888888; +86-752-5118888

http: // [www.byd.com.cn](http://www.byd.com.cn)



■ Applications

- Automotive light
- Day time running light
- Camera Flash and Video Light
- Torch Light

■ Device Selection Guide

Model No.	Chip		Epoxy Color
	Material	Emitting Color	
BOF-2016WD-DY15-60	InGaN	White	Yellow Diffused

LED 胶体为软硅胶封装，请避免外力碰撞。

■ Package Outline Dimensions

Dimensions: 2.04(L) × 1.64(W) × 0.80(H) mm.

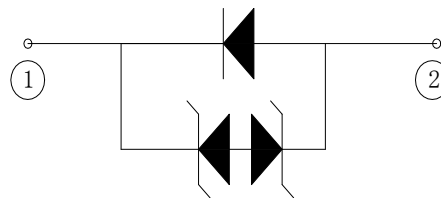
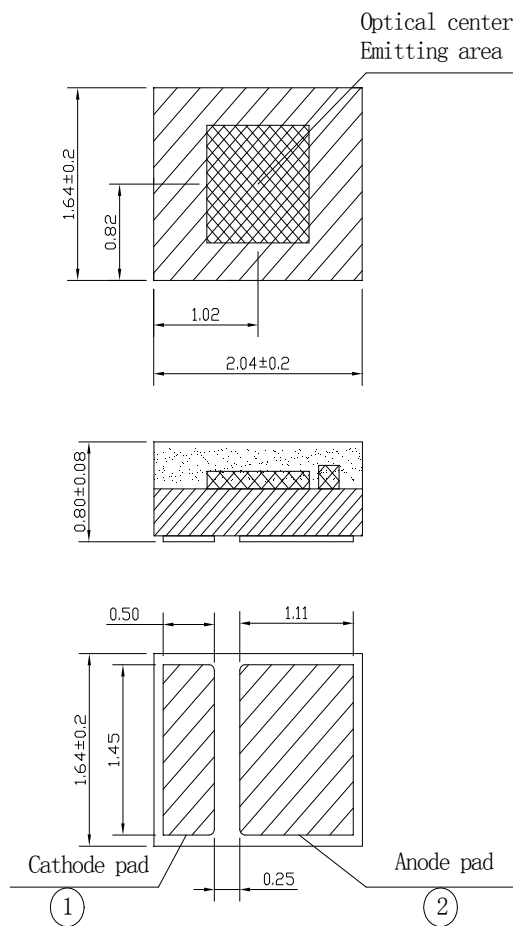

Recommended Solder pattern

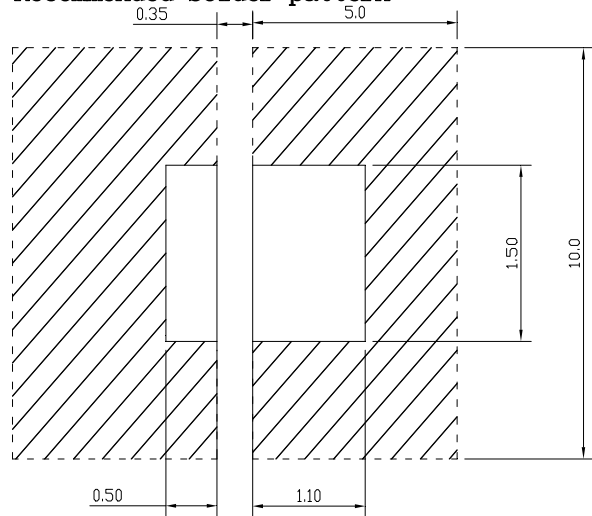

□ foot print  
 Cu area + solder resist  
 Recommended >10\*10mm

Note:

1. Dimensions are in millimeters.
2. Tolerances unless mentioned are ± 0.1mm.
3. Emitting area: 1.15\*1.15±0.1mm



■ Absolute Maximum Ratings (Ta=25° C)

Items	Symbol	Absolute Maximum Ratings	Unit
Power Dissipation	P <sub>d</sub>	3.6	W
Junction Temperature	T <sub>j</sub>	150	°C
Forward Current(DC)	I <sub>F</sub>	1200	mA
Peak Forward Current* ( 200ms : on , 1800ms : off)	I <sub>FP</sub>	1500	mA
Operation Temperature	T <sub>opr</sub>	-40 ~ +125	°C
Storage Temperature	T <sub>stg</sub>	-40 ~ +125	°C
Wavelength	Wp	435 ~ 460	nm
Wavelength	Wd	450 ~600	nm
Ra	Ra	≥60	nm
50% Power Angle	2θ <sub>1/2</sub>	110 ~120 ~130	deg
Thermal resistance junction/board	Rth	≤5	k/w
ESD ( HBM )	ESD	≥8	Kv
Lead Soldering Temperature	T <sub>sol</sub>	260°C for 5 Seconds	

\*Pulse Width ≤200ms and Duty ≤1/10 ;

All reliability items are tested under good thermal management with 16x 16 mm<sup>2</sup> MPCB of >3W/m.K , Ts<125°C.

■ Typical Electrical & Optical Characteristics (Ta=25°C)

Items	Symbol	Condition	Min.	Typ.	Max.	Unit
Forward Voltage	V <sub>F</sub>	I <sub>F</sub> =350mA	2.8	3.1	3.4	V
	V <sub>F</sub>	I <sub>F</sub> =1000mA	2.8	3.3	3.6	V
Reverse Current	I <sub>R</sub>	V <sub>R</sub> =-5v	---	---	5	uA
Chromaticity Coordinate	(x, y)	I <sub>F</sub> =350mA	0.31/0.31	0.329/0.345	0.349/ 0.372	---
	(x, y)	I <sub>F</sub> =1000mA	0.31/0.31	0.325/0.335	0.345/ 0.367	---
Luminous Flux	φ <sub>v</sub>	I <sub>F</sub> =350mA	70	140	---	Lm
	φ <sub>v</sub>	I <sub>F</sub> =1000mA	260	330	---	Lm

■ Ranks Combination (I<sub>F</sub> =1000mA)

φV /Lm	Q:260-300	R: 300-350	S: 350-400	/
VF/v	G2: 2.8-3.0	H2: 3.0-3.2	I2: 3.2-3.4	/
CHC	W3	W4	W5	W45

Notes:

- \*Tolerance of measurement of Luminous Flux is ±15%;
- \*Tolerance of measurement of forward voltage is ± 0.2V;
- \*Tolerance of measurement of I<sub>r</sub> is ± 3uA;
- \*Tolerance of measurement of I<sub>f</sub> is ± 5%;
- \*Chromaticity Coordinate s measurement allowance : ±0.015.



■ Chromaticity coordinate(IF=1000mA)

白光坐标范围

	x	y
W3	0.3430	0.3590
	0.3345	0.3670
	0.3270	0.3530
	0.3355	0.3450
W4	0.3355	0.3450
	0.3270	0.3530
	0.3195	0.3390
	0.3280	0.3310

	x	y
W5	0.3280	0.3310
	0.3195	0.3390
	0.3120	0.3250
	0.3205	0.3170
W6	0.3205	0.3170
	0.3120	0.3250
	0.3083	0.3180
	0.3168	0.3100

	x	y
W45	0.3185	0.3372
	0.3204	0.3407
	0.3289	0.3327
	0.3270	0.3292

■ CIE Graph

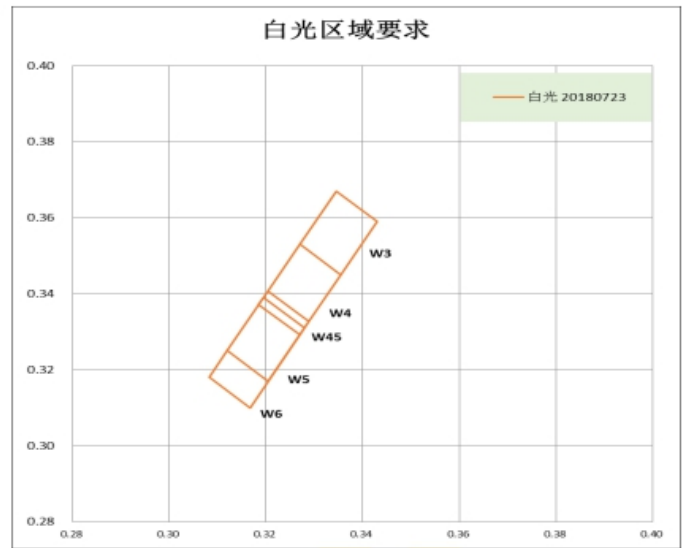
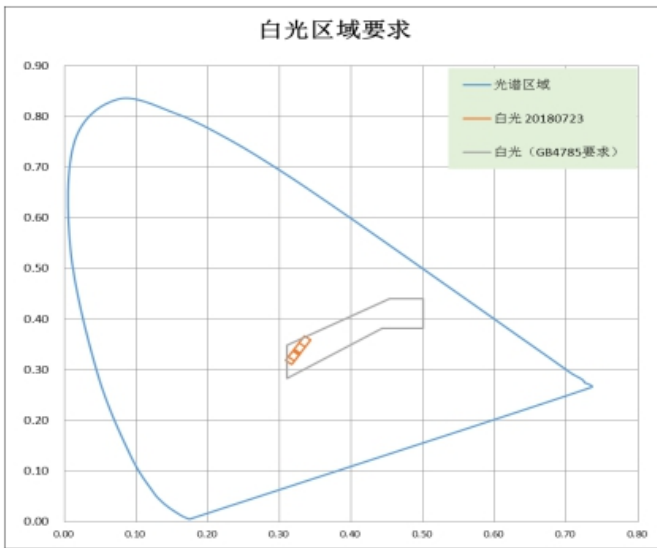

Note:

- 1、Percentage of red:>5% acc.to GB 25991 regulation.
- 2、Percentage of UV: <10-5 W/lm acc. to GB 25991 regulation.
- 3、Acc. to white area GB 4785 2007.



■ Reliability

1) Test Items and Results:

Classifi- cation	Test Item	Standard Test Method	Test Conditions	Duration	Units Tested	Number Of Damaged
Life Test	Operating Life Test *	JIS7021:B4 MIL-STD-202:107D MIL-STD-750:1026	Ta=85±5°C, IF=1200mA *	1000Hrs	11	0/11
		JESD22-A101	Ta=85±5°C RH=85±5%RH IF=1200mA *	1000 Hrs	11	0/11
Environment Test	High Temperature Storage	JIS7021:B10 MIL- STD-202:210A MIL- STD-750:2031	Ta=100±5°C	1000Hrs	11	0/11
	Low Temperature Storage	JIS7021:B12	Ta= -40±5°C	1000Hrs	11	0/11
	Temp. & Humidity Test	JIS7021:B11 MIL-STD-202:103D	Ta=85±5°C RH=85±5%RH	1000Hrs	11	0/11
	Thermal Shock Test	JIS7021B4 MIL-STD-202:107D MIL-STD-750:1026	-40°C ← - → 125°C 15min 10sec 15min	1000 Cycles	11	0/11
	ESD	JEDEC JS-001: HMB	8KV	10 Cycles	11	0/11
Solder ing Test	Resistance to soldering	-	Tsol=260±5°C, 10sec	3 time	22	0/22

\* All reliability items are tested under good thermal management with 16x 16 mm<sup>2</sup> MPCB of >3W/m.K. Ts<125°C.

2) Criteria for Judge The Damage:

Items	Symbol	Condition	Criteria for Judge	
			Min.	Max.
Forward Voltage	V <sub>F</sub>	I <sub>F</sub> =1000mA	---	initial value x 1.2
Reverse Current	I <sub>R</sub>	V <sub>R</sub> =5V	---	not designed for reverse operation
Luminous Flux (Lm)	Φ <sub>v</sub>	I <sub>F</sub> =1000mA	initial value x 0.85	---



■ Typical Electrical / Optical Characteristics Curves

(Ta = 25°C Unless Otherwise Noted)

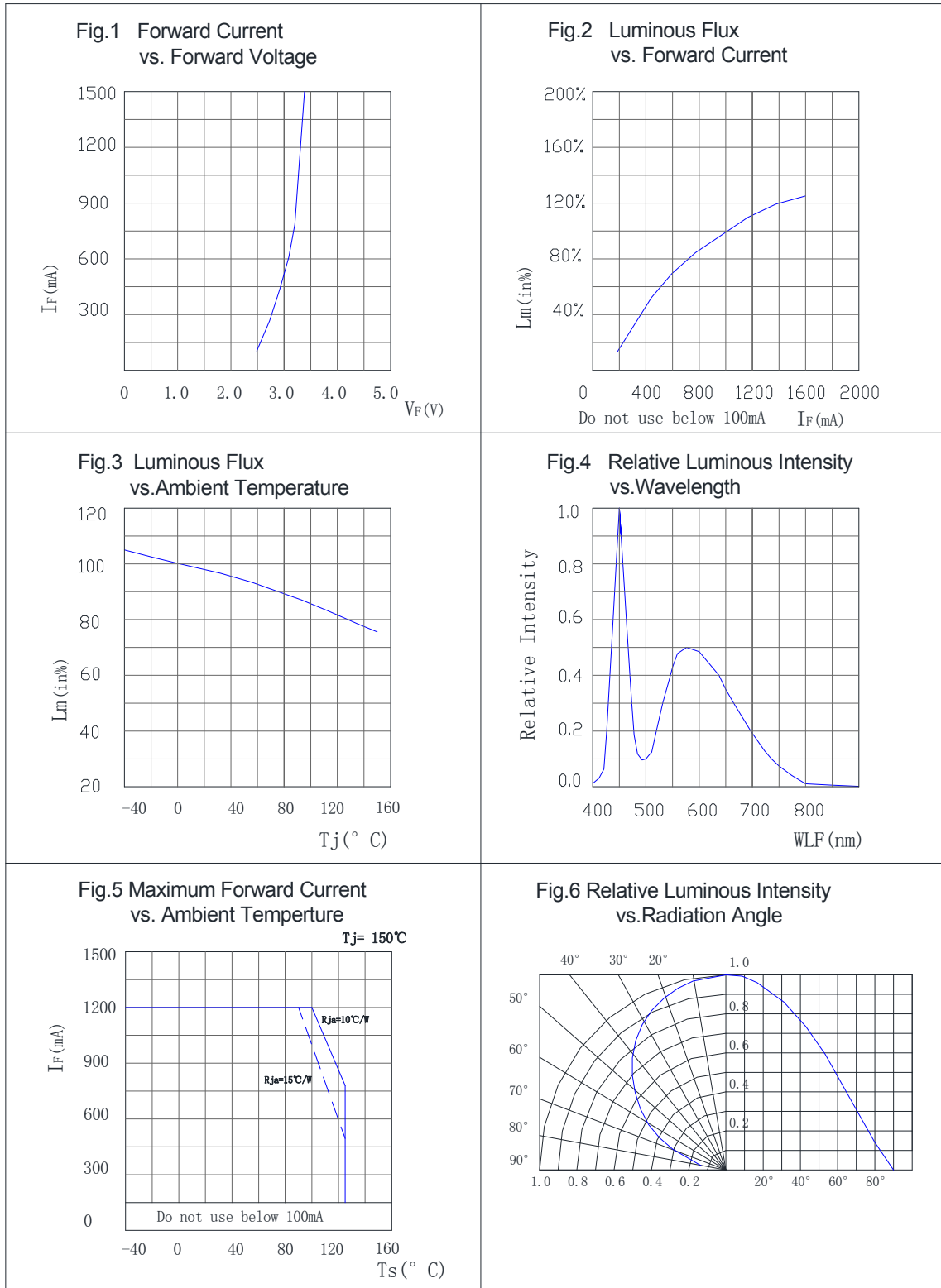



■ Reel Specification:

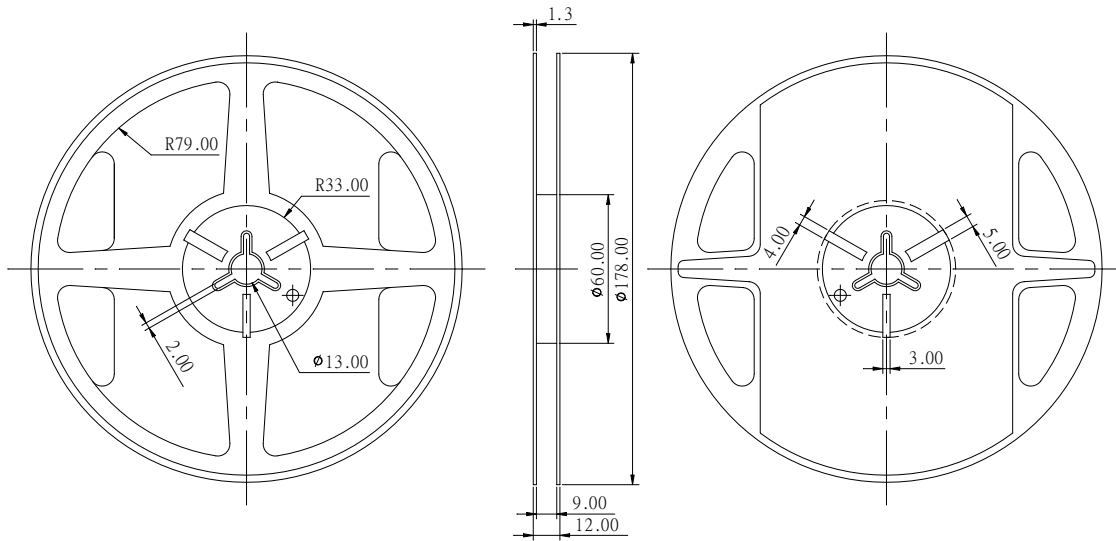

■ Taping Specification - ( 500 , or1000, or2000pcs / reel )

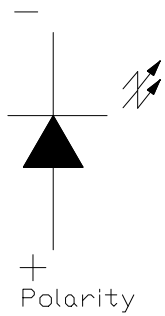
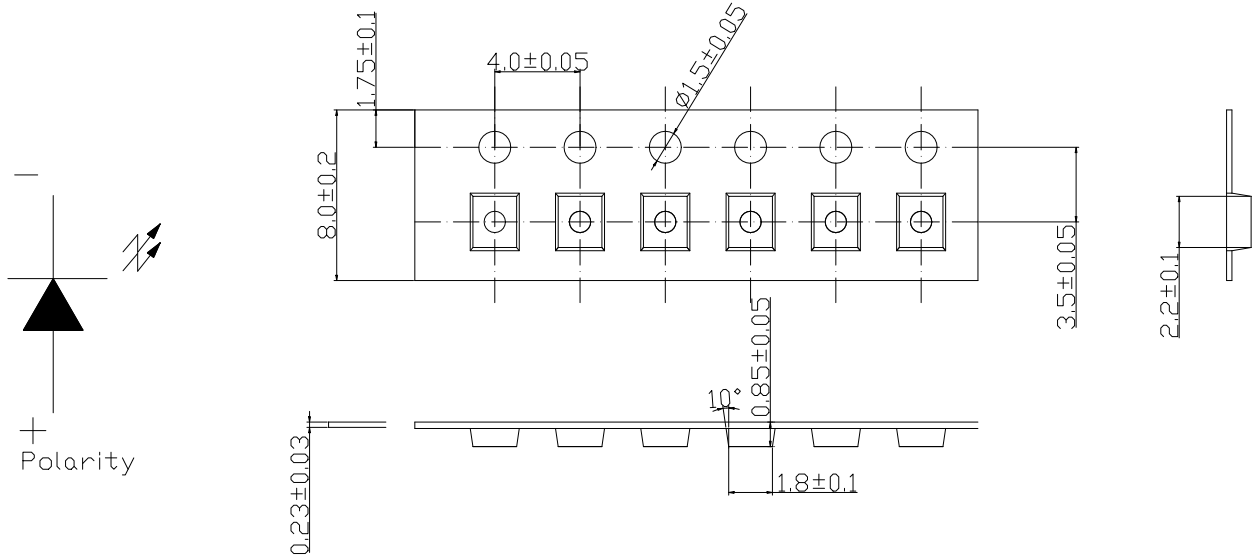

## ■ Packing Type

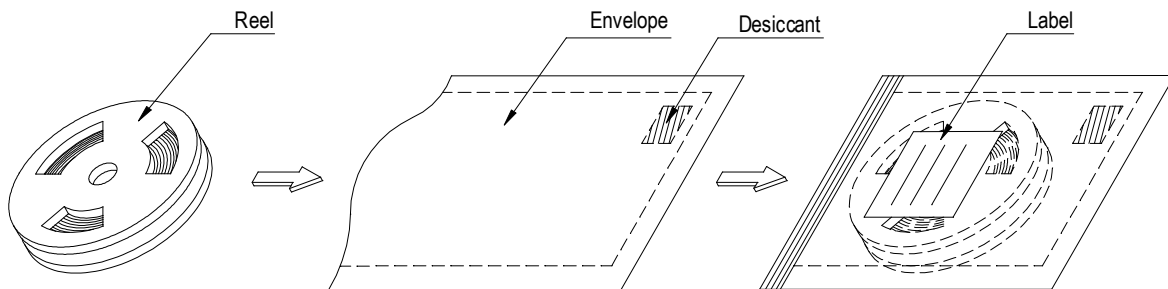

## ■ Precautions For Use

### 1. Over - current - proof

Customer must apply resistors for protection, otherwise slight voltage shift will cause big current change (Burn out will happen).

### 2. Storage

- 2.1 Do not open moisture proof bag before the products are ready to use;
- 2.2 The LEDs should be kept at 30°C or less and 70%RH or less, and the storage life limits are 12 months;
- 2.3 Product complies to MSL Level 2 acc.to JEDEC J-STD-020E.

### 3. Soldering

#### 3.1 Reflow Soldering / Time

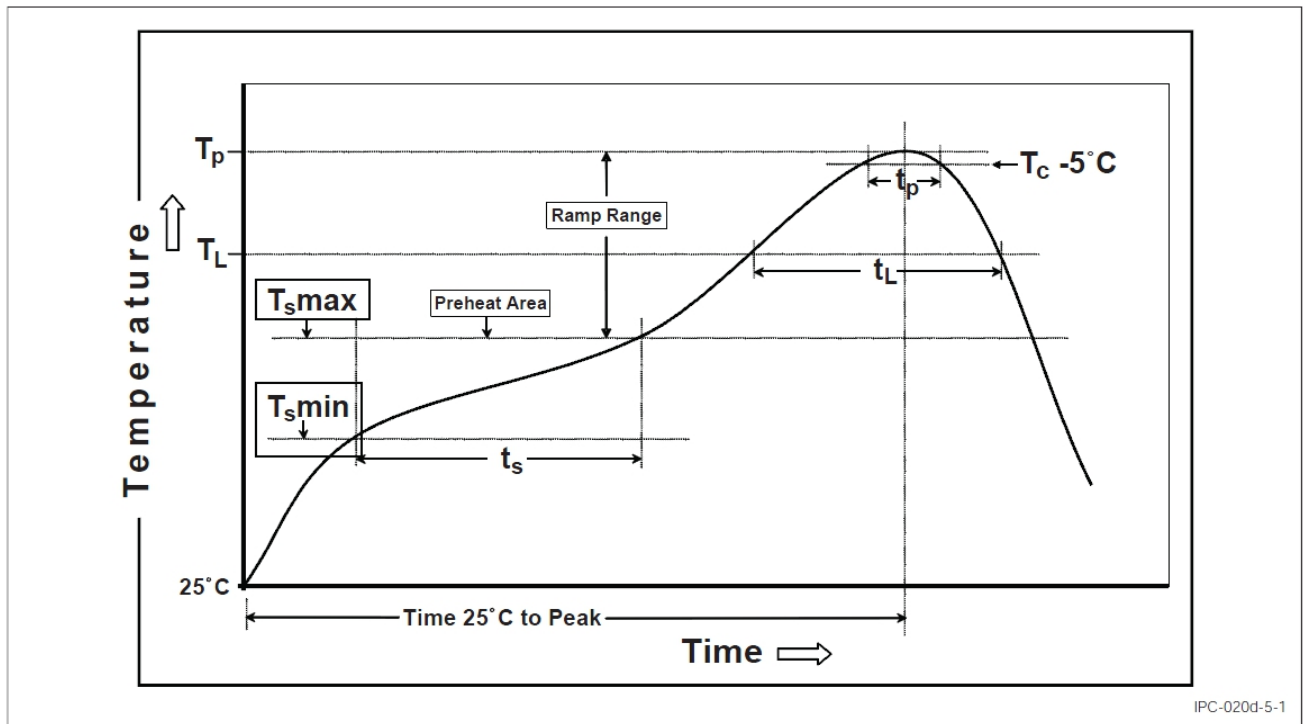





## 2016WD-DY15-60

Profile Feature	Sn-Pb Eutectic Assembly	Pb-Free Assembly
Preheat & Soak		
Temperature Min (T <sub>min</sub> )	100° C	150° C
Temperature Max (T <sub>max</sub> )	150° C	200° C
Time (T <sub>min</sub> to T <sub>max</sub> ) (ts)	60-120 seconds	60-120 seconds
Average ramp-up rate (T <sub>max</sub> to T <sub>p</sub> )	3° C/second max.	3° C/second max.
Liquidous Temperature (TL) Time at Liquidous (tL)	183° C/60-150 seconds	217° C/60-150 seconds
Peak Package Body Temperature (T <sub>p</sub> )*	235° C max.	260° C max.
Time (t <sub>p</sub> )** within 5° C of the specified classification Temperature (T <sub>c</sub> )	10 seconds max	10 seconds max
Average ramp-down Rate (T <sub>p</sub> to T <sub>max</sub> )	6° C/second max.	6° C/second max.
Time 25° C to Peak Temperature	6 minutes max.	8 minutes max.

- 3.2 Reflow soldering should not be done more than two times;
- 3.3 While soldering, do not put stress on the LEDs during heating;
- 3.4 After soldering, do not warp the circuit board.

#### 4. Caution in ESD

- 4.1 Electrostatic discharge (ESD) and surge current (EOS) can damage LEDs;
- 4.2 An ESD wrist strap, ESD shoe strap or antistatic gloves must be worn whenever handling LEDs;
- 4.3 All devices equipment and machinery must be properly grounded.

#### 5. Other

- 5.1 Above specification may be changed without notice. BYD will reserve authority on material change for above specification;
- 5.2 When using this product, please observe the absolute maximum ratings and the instructions for using outlined in these specification. BYD assumes no responsibility for any damage resulting from use of the product which does not comply with the absolute maximum ratings and the instructions included in these specification.

**RESTRICTIONS ON PRODUCT USE**

- The information contained herein is subject to change without notice.
- **BYD Semiconductor Company Limited** exerts the greatest possible effort to ensure high quality and reliability. Nevertheless, semiconductor devices in general can malfunction or fail due to their inherent electrical sensitivity and vulnerability to physical stress. It is the responsibility of the buyer, when utilizing products, to comply with the standards of safety in making a safe design for the entire system, including redundancy, fire-prevention measures, and malfunction prevention, to prevent any accidents, fires, or community damage that may ensue. In developing your designs, please ensure that products are used within specified operating ranges as set forth in the most recent products specifications.
- The products listed in this document are intended for usage in general electronics applications (computer, personal equipment, office equipment, measuring equipment, industrial robotics, domestic appliances, etc.). These products are neither intended nor warranted for usage in equipment that requires extraordinarily high quality and/or reliability or a malfunction or failure of which may cause loss of human life or bodily injury (“Unintended Usage”). Unintended Usage include atomic energy control instruments, airplane or spaceship instruments, transportation instruments, traffic signal instruments, combustion control instruments, medical instruments, all types of safety devices, etc.. Unintended Usage of products listed in this document shall be made at the customer’s own risk.