

□ General Description

This IGBT module, which adopts general packaging, can meet Auto-grade standards and is specially developed for new energy motor controller, and which provides low switching loss as well as high short circuit capability, which introduce the advanced FS IGBT chip and ultra fast & soft recovery anti-parallel FRD to improved connection, it is able to take on a perfect performance in various applications up to 16KHz. In order to adapt to the complex automotive application environment at the same time, the module framework adopts PPS material with better performance, higher temperature resistance, not easily deformed, higher corrosion resistance.

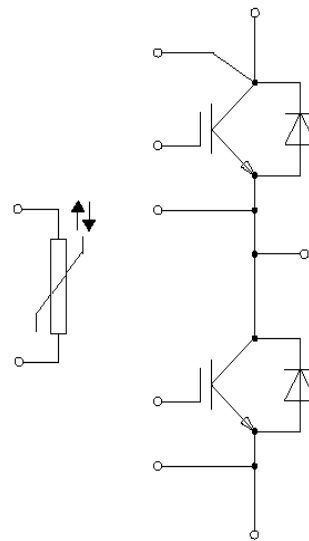
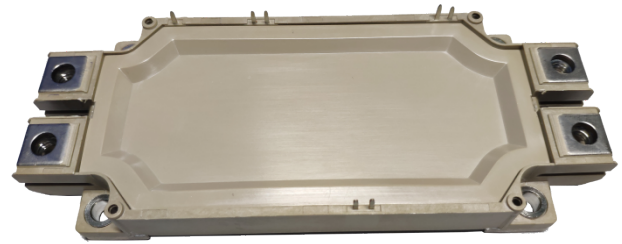

□ 概述

这款 IGBT 模块采用了标准封装,可以满足汽车级标准,专为新能源汽车控制器设计,并且提供低损和高短路能力,内含先进的平面栅场终止技术 IGBT 和超快速软恢复二极管芯片,在不超过 16KHz 频率的应用中表现出优良的性能。同时为了适应复杂的车用环境,模块外框材料采用了特性更好的 PPS 材料,具有更好的耐热性能,不易变形,耐腐蚀性等优点,可确保模块的高质量及可靠性。

□ Key Features

- Half-bridge module
- 1200V planar&field stop technology
- High short circuit capability
- Ultra low conduction and switching loss
- Including ultra fast&soft recovery anti-parallel FRD

□ Applications

- AC motor control
- Inverters
- Solar application
- Automotive application

□ IGBT/IGBT

- Maximum Rated Values/最大额定值

□ 关键特性

- 半桥模块
- 1200V 平面栅场终止技术
- 高短路能力
- 低导通和开关损耗
- 反并联超快速软恢复二极管

□ 应用

- 交流马达控制
- 逆变器
- 光伏领域
- 汽车领域



Parameter	Symbol	Conditions	Values	Units
Collector-emitter voltage 集电极-发射极电压	V_{CES}	$T_{vj}=25^{\circ}C, V_{GE}=0V$	1200	V
Continuous collector current 连续集电极直流电流	I_C	$T_c=25^{\circ}C, T_{vj}=175^{\circ}C$	1200	A
	$I_{C\ nom}$	$T_c=100^{\circ}C, T_{vj}=175^{\circ}C$	600	A
Gate-emitter voltage 栅极-发射极电压	V_{GES}	$T_{vj}=25^{\circ}C$	± 20	V
Peak collector current 集电极峰值电流	I_{CRM}	$t_p=1ms, T_{vj}=25^{\circ}C$	1200	A
SC data 短路数据	I_{SC}	$V_{GE}\leq 15V, V_{CC}=800V$ $V_{CEmax}=V_{CES} - L_{sCE} * di/dt$ $t_p\leq 10\mu s, T_{vj}=150^{\circ}C$	2400	A
Total power dissipation 总耗散功率	P_{tot}	$T_c=25^{\circ}C, T_{vj}=175^{\circ}C$	3570	W

● Characteristics Values/特征值

Parameter	Symbol	Conditions	Values			Units
			Min.	Typ.	Max.	
Collector-Emitter Saturation Voltage 集电极-发射极饱和电压	V_{CEsat}	$I_C=600A, V_{GE}=15V, T_{vj}=25^{\circ}C$	-	2.30	2.70	V
		$I_C=600A, V_{GE}=15V, T_{vj}=125^{\circ}C$	-	2.50	-	V
		$I_C=600A, V_{GE}=15V, T_{vj}=150^{\circ}C$	-	2.57	-	V
Gate-emitter threshold voltage 栅极-发射极阈值电压	V_{Geth}	$V_{CE}=V_{GE}, I_C=18mA, T_{vj}=25^{\circ}C$	5.0	6.2	7.0	V
Gate charge 栅极电荷	Q_G	$V_{GE}=-15V...+15V$	-	1.8	-	μC
Internal gate resistor 内部栅极电阻	R_{gint}	$T_{vj}=25^{\circ}C$	-	1.3	-	Ω
Input capacitance 输入电容	C_{ies}	$T_{vj}=25^{\circ}C, f=1MHz, V_{GE}=0V, V_{CE}=25V$	-	17	-	nF
Reverse transfer capacitance 反向传输电容	C_{res}		-	0.8	-	nF
Collector-emitter cut-off current 集电极-发射极截止电流	I_{CES}	$V_{CE}=1200V, V_{GE}=0V, T_{vj}=25^{\circ}C$	-	-	1	mA

Parameter	Symbol	Conditions	Values	Units
-----------	--------	------------	--------	-------



			Min.	Typ.	Max.		
Gate-emitter leakage current 栅极-发射极漏电流	I_{GES}	$V_{CE}=0V, V_{GE}=20V, T_{vj}=25^{\circ}C$	-	-	400	nA	
Turn-on delay time 开通延迟时间	t_{don}	$I_C = 600 A,$ $V_{CE} = 600 V,$ $V_{GE} = -8V \dots +15 V,$ $R_{Gon} = 1\Omega,$ $R_{Goff} = 1\Omega,$ $L_s = 40nH$	$T_{vj}=25^{\circ}C$	-	110	-	ns
			$T_{vj}=125^{\circ}C$	-	140	-	ns
			$T_{vj}=150^{\circ}C$	-	140	-	ns
Rise time 上升时间	t_r		$T_{vj}=25^{\circ}C$	-	90	-	ns
			$T_{vj}=125^{\circ}C$	-	100	-	ns
			$T_{vj}=150^{\circ}C$	-	110	-	ns
Turn-off delay time, 关断延迟时间	t_{doff}		$T_{vj}=25^{\circ}C$	-	340	-	ns
			$T_{vj}=125^{\circ}C$	-	400	-	ns
			$T_{vj}=150^{\circ}C$	-	420	-	ns
Fall time 下降时间	t_f		$T_{vj}=25^{\circ}C$	-	50	-	ns
			$T_{vj}=125^{\circ}C$	-	130	-	ns
			$T_{vj}=150^{\circ}C$	-	230	-	ns
Turn-on energy loss 开通损耗	E_{on}	$T_{vj}=25^{\circ}C$	-	65	-	mJ	
		$T_{vj}=125^{\circ}C$	-	75	-	mJ	
		$T_{vj}=150^{\circ}C$	-	80	-	mJ	
Turn-off energy loss 关断损耗	E_{off}	$T_{vj}=25^{\circ}C$	-	22	-	mJ	
		$T_{vj}=125^{\circ}C$	-	40	-	mJ	
		$T_{vj}=150^{\circ}C$	-	50	-	mJ	

□ FRD/二极管

● Maximum Rated Values/最大额定值

Parameter	Symbol	Conditions	Values	Units
Repetitive peak reverse voltage 反向重复峰值电压	V_{RRM}	$T_{vj}=25^{\circ}C$	1200	V
Diode DC forward current 二极管直流正向电流	I_F	$T_C=25^{\circ}C$	600	A
Repetitive peak forward current 正向重复峰值电流	I_{FRM}	$t_p=1ms, T_{vj}=25^{\circ}C$	1200	A
I^2t -value I^2t -值	I^2t	$V_R=0V, t_p=10ms, T_{vj}=125^{\circ}C$ $V_R=0V, t_p=10ms, T_{vj}=150^{\circ}C$	45000 36000	A ² s



● Characteristics Values/特征值

Parameter	Symbol	Conditions	Values			Units	
			Min.	Typ.	Max.		
Forward voltage 正向电压	V_F	$I_F=600A,$ $V_{GE}=0V$	$T_{vj}=25^{\circ}C$	-	1.98	2.50	V
			$T_{vj}=125^{\circ}C$	-	2.11	-	V
			$T_{vj}=150^{\circ}C$	-	2.03	-	V
Peak reverse recovery current 反向恢复峰值电流	I_{RM}	$I_F=600 A,$	$T_{vj}=25^{\circ}C$	-	180	-	A
			$T_{vj}=125^{\circ}C$	-	260	-	A
			$T_{vj}=150^{\circ}C$	-	280	-	A
Recovered charge 恢复电荷	Q_r	$V_R = 600 V,$ $V_{GE}=-8V...+15V,$ $di/dt=4600A/us$ ($T_{vj}=150^{\circ}C$)	$T_{vj}=25^{\circ}C$	-	30	-	μC
			$T_{vj}=125^{\circ}C$	-	45	-	μC
			$T_{vj}=150^{\circ}C$	-	60	-	μC
Reverse recovery energy 反向恢复损耗	E_{rec}	$(T_{vj}=150^{\circ}C)$	$T_{vj}=25^{\circ}C$	-	10	-	mJ
			$T_{vj}=125^{\circ}C$	-	20	-	mJ
			$T_{vj}=150^{\circ}C$	-	25	-	mJ

□ Module/模块

Parameter	Symbol	Conditions	Values			Units
			Min.	Typ.	Max.	
Maximum junction temperature 最大结温	T_{vjmax}	-	-	-	175	$^{\circ}C$
Temperature under switching conditions 开关状态下温度	T_{vjop}	-	-40	-	150	$^{\circ}C$
Storage temperature 储存温度	T_{stg}	-	-40	-	150	$^{\circ}C$
IGBT, thermal resistance, junction to case 结-外壳热阻	$R_{thjc IGBT}$	per IGBT 每个 IGBT	-	-	0.042	K/W
Diode, thermal resistance, junction to case 结-外壳热阻	$R_{thjc Diode}$	per diode 每个二极管	-	-	0.117	K/W
Stray inductance module 模块杂散电感	L_{sCE}	-	-	31	-	nH
Module lead resistance, terminals - chip 模块引线电阻,端子-芯片	$R_{CC'+EE'}$	$T_{vj}=25^{\circ}C$, per switch	-	1.2	-	m Ω
Isolation test voltage 绝缘测试电压	V_{isol}	AC, RMS, f = 50Hz, t = 1min.	3	-	-	kV
Weight	G	-	-	338	-	g



重量						
----	--	--	--	--	--	--

Parameter	Symbol	Conditions	Values			Units
			Min.	Typ.	Max.	
Creepage distance 爬电距离	ds	Terminal to terminal 端子到端子	-	13.0	-	mm
		Terminal to base 端子到基板	-	14.5	-	
Clearance distance in air 空气间隙	da	Terminal to terminal 端子到端子	-	10.0	-	mm
		Terminal to base 端子到基板	-	12.5	-	
Mounting torque for module mounting 模块的安装扭矩	M ₁	Screw M5 M5 螺栓	3	-	6	N.m
Terminal connection torque 端子的连接扭矩	M ₂	Screw M6 M6 螺栓	3	-	6	N.m
Internal isolation 内部绝缘	-	ceramics 陶瓷	Al ₂ O ₃			-
Material of module baseplate 模块基板材料	-	-	Cu			-
Dimensions 尺寸	L x W x H	-	152.1×62×21			mm

□ NTC-Thermistor/负温度系数热敏电阻

Parameter	Symbol	Conditions	Values			Units
			Min.	Typ.	Max.	
Rated resistance 额定电阻值	R ₂₅	T _C =25℃	-	5.0	-	KΩ
Deviation of R100 R100 偏差	ΔR/R	T _C =100℃, R ₁₀₀ =493Ω	-5	-	5	%
Power dissipation 耗散功率	P ₂₅	T _C =25℃	-	-	20	mW
B-value/B-值	B _{25/50}	$R_2=R_{25}\exp[B_{25/50}(1/T_2-1/(298.15K))]$	-	3375	-	K
B-value/ B-值	B _{25/80}	$R_2=R_{25}\exp[B_{25/80}(1/T_2-1/(298.15K))]$	-	3411	-	K
B-value/ B-值	B _{25/100}	$R_2=R_{25}\exp[B_{25/100}(1/T_2-1/(298.15K))]$	-	3433	-	K

Characteristics Diagrams/特性曲线

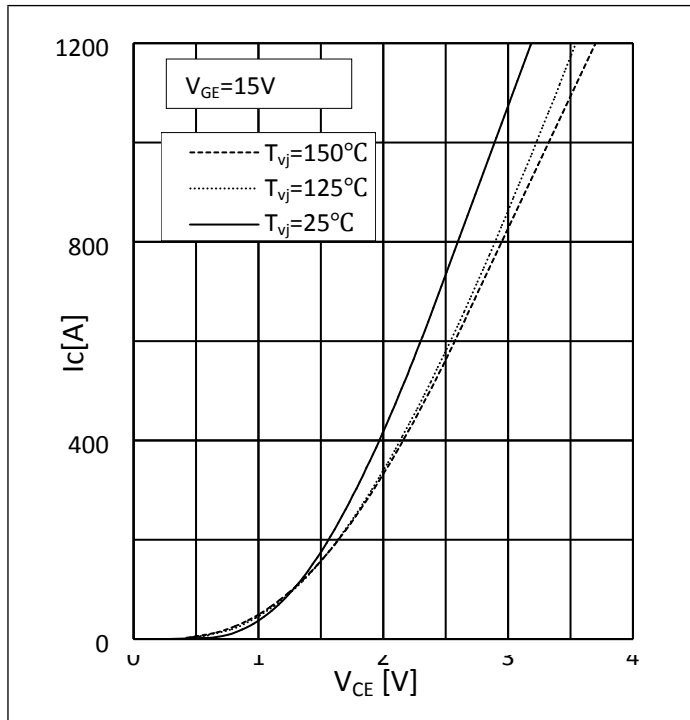

Fig.1: Output Characteristics
图 1: 输出特性

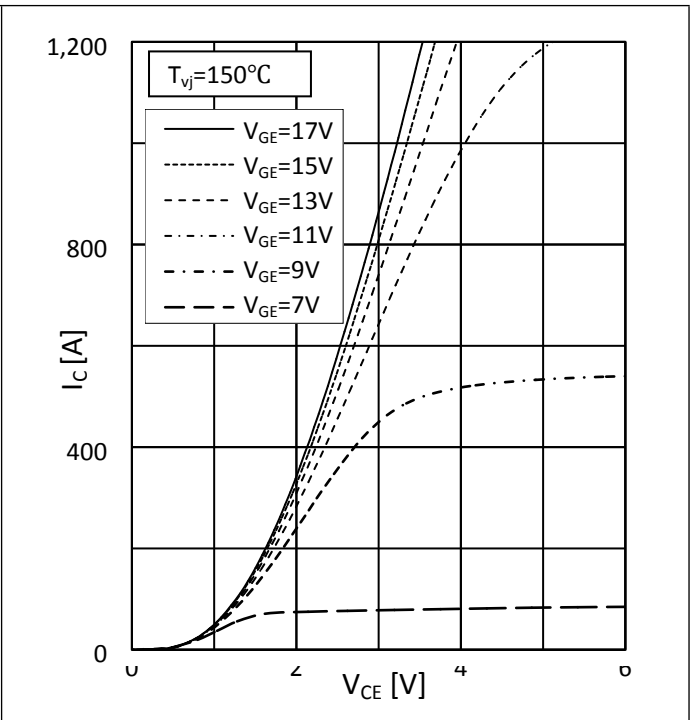

Fig.2: Output characteristics
图 2: 输出特性

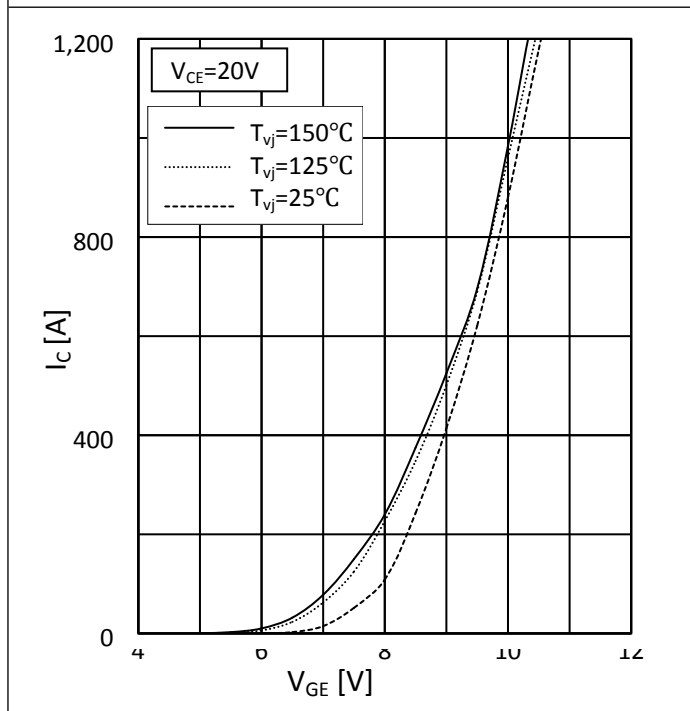

Fig.3: Transfer Characteristics
图 3: 传输特性

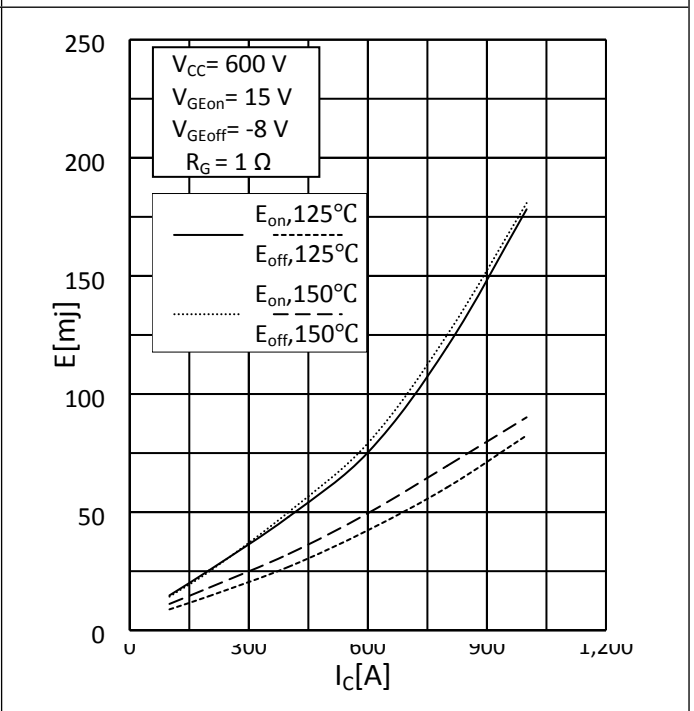

Fig.4: Switching Loss vs. Collector Current
图 4: 开关损耗与集电极电流关系

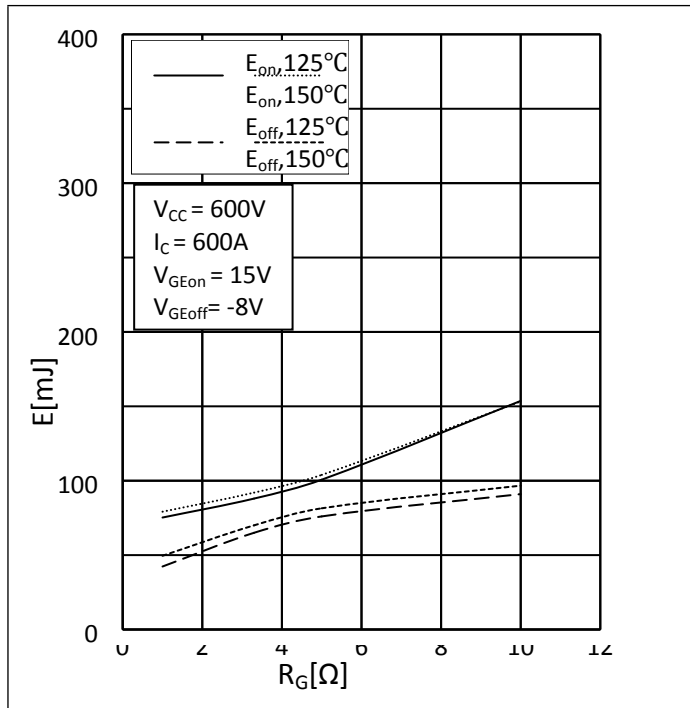

Fig.5: Switching Loss vs. Gate Resistor
图 5: 开关损耗与门极电阻关系

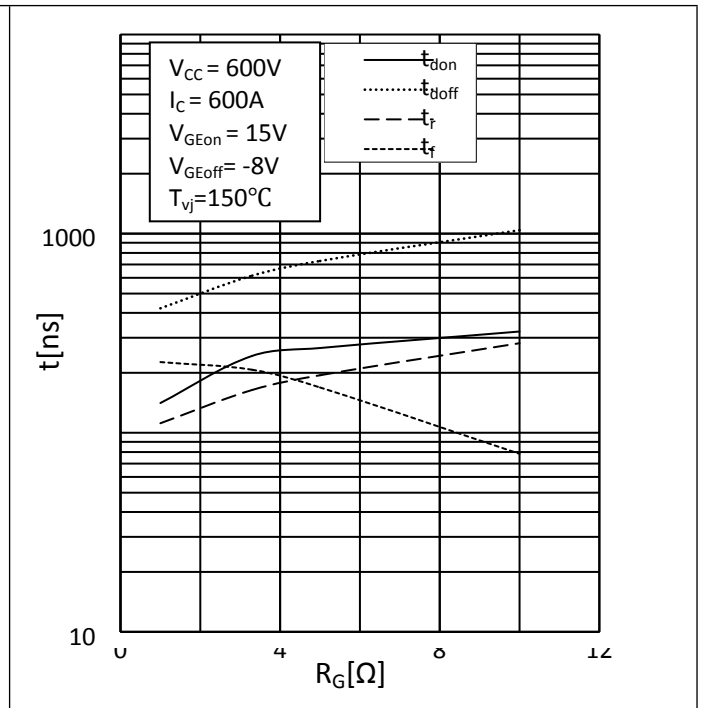

Fig.6: Switching Times vs. Gate Resistor
图 6: 开关时间与门极电阻关系

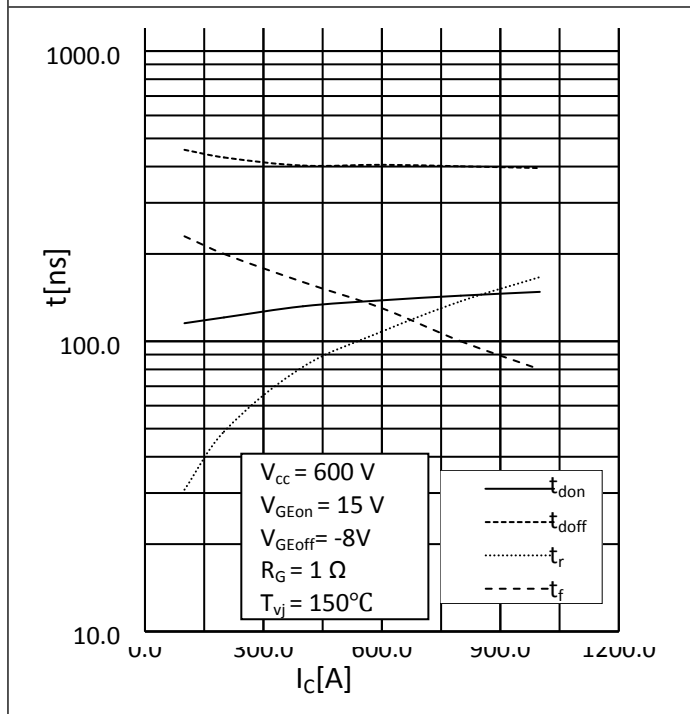

Fig.7: Switching Times vs. I_C
图 7: 开关时间与集电极电流关系

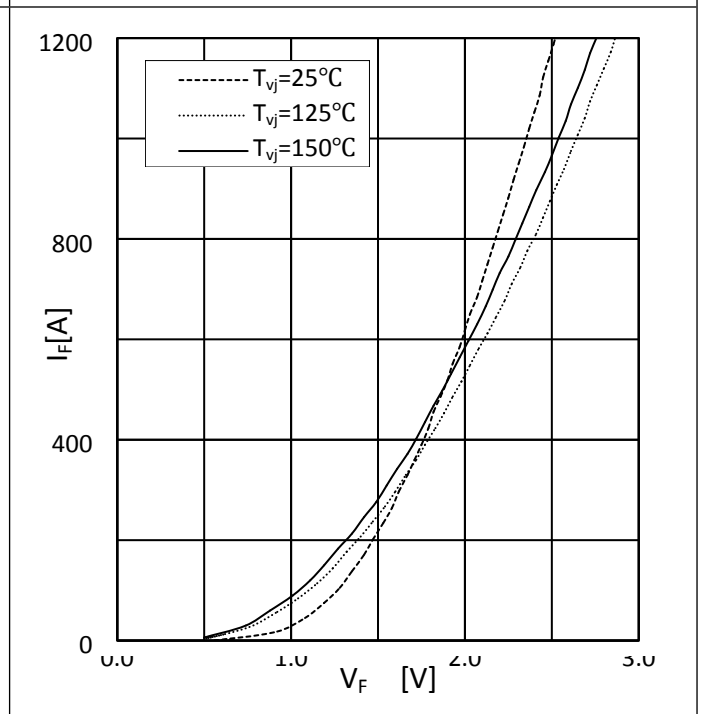

Fig.8: Forward characteristic
图 8: 正向特性

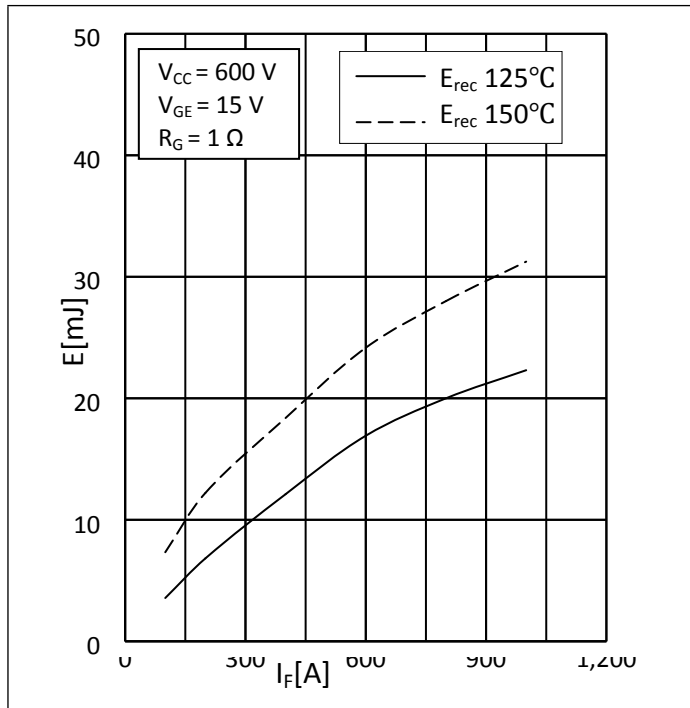

Fig.9: Reverse recovery Energy

图 9: 反向恢复损耗

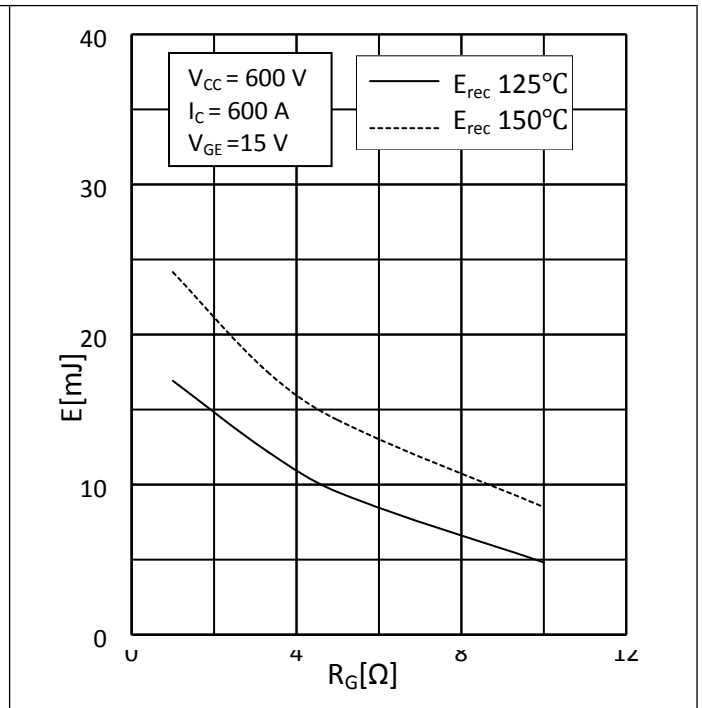

Fig.10: Reverse recovery Energy vs. Gate Resistor

图 10: 反向恢复损耗与门极电阻关系

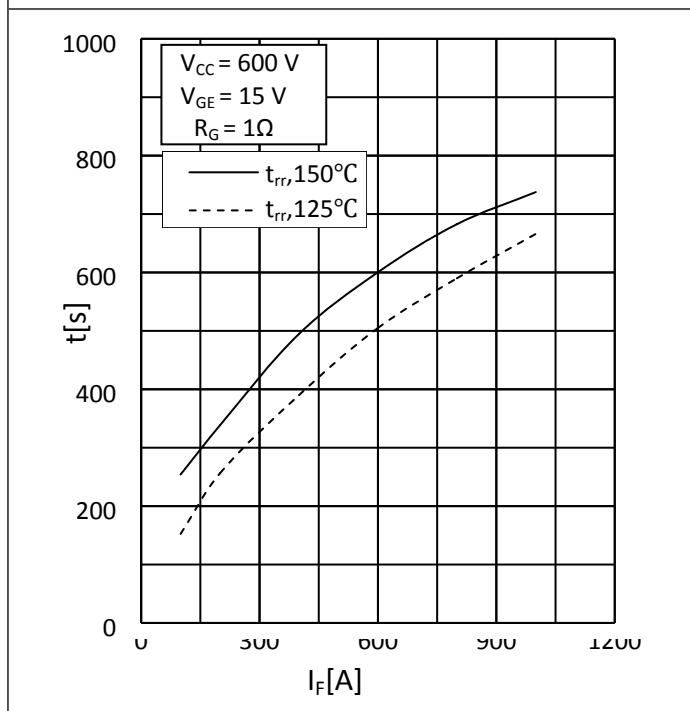

Fig.11: Reverse Recovery Times vs. I_F

图 11: 反向恢复时间与正向电流关系

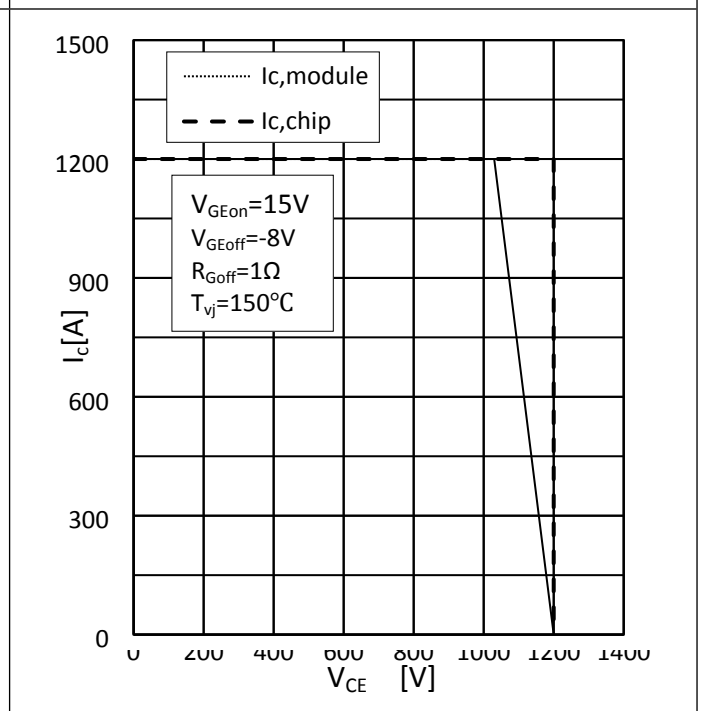

Fig.12: Reverse Bias Safe Operating Area

图 12: 反偏安全工作区

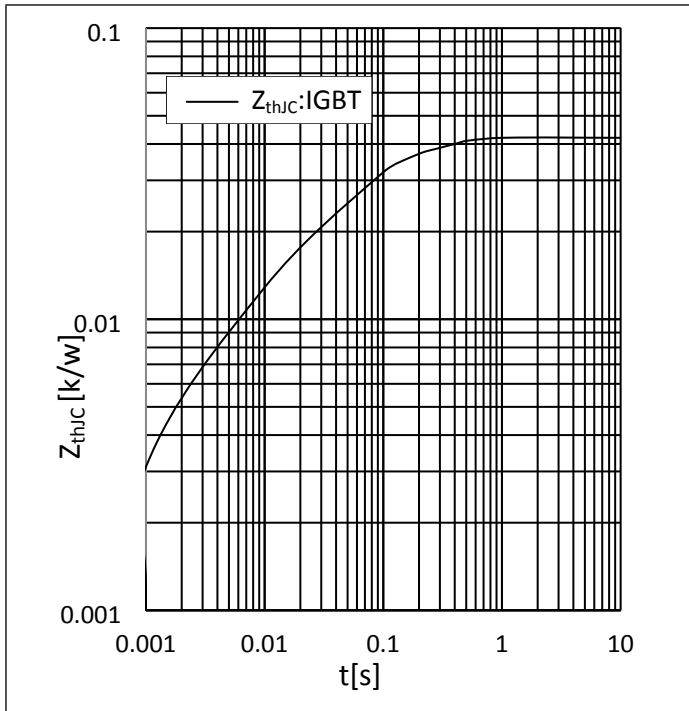

Fig.13: Typ. transient thermal impedance(IGBT) Z_{thJC} IGBT(K/W)

图 13: 典型的瞬态热阻抗(IGBT) Z_{thJC} IGBT(K/W)

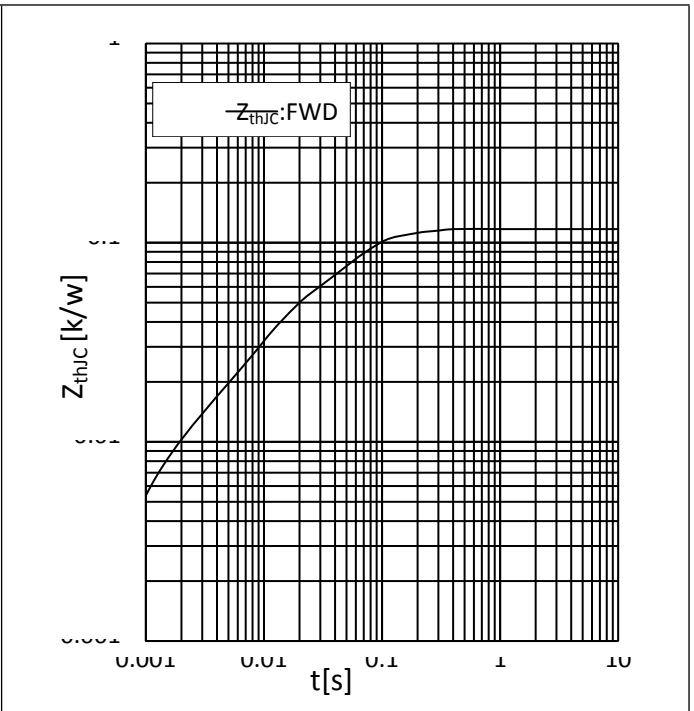

Fig.14: Typ. transient thermal impedance(FWD) Z_{thJC} FWD(K/W)

图 14: 典型的瞬态热阻抗(FWD) Z_{thJC} FWD(K/W)

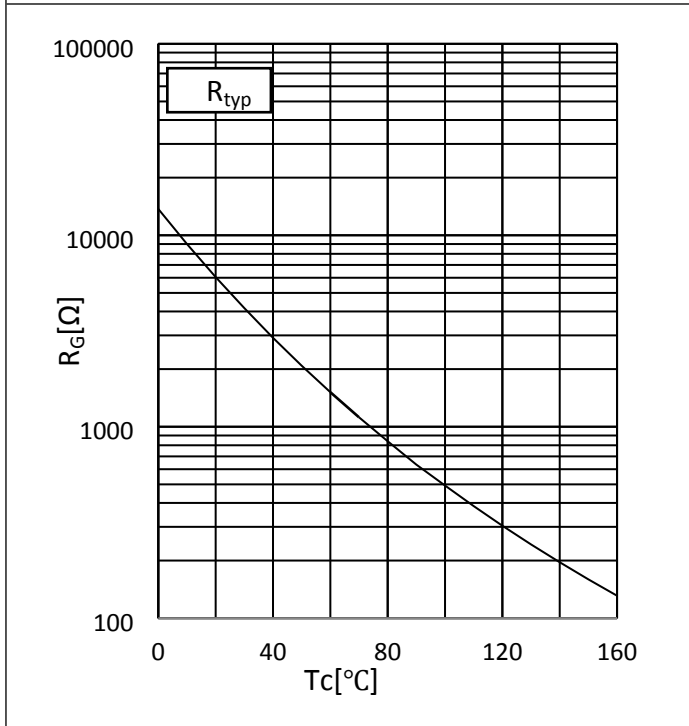
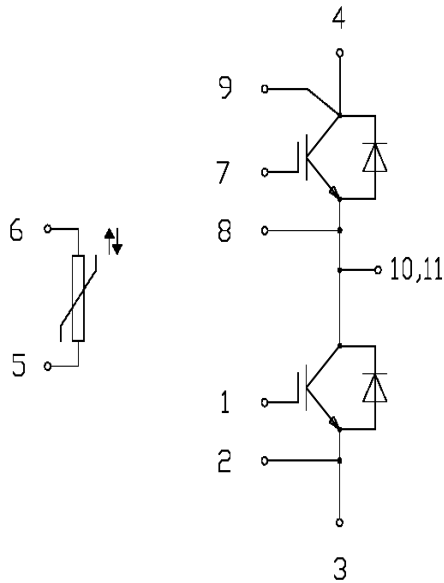

Fig.15:Typ. NTC-Temperature Characteristics

图 15: 典型的 NTC 电阻-温度特性

Circuit Diagram/接线图



- | | |
|----------------------|----------------|
| (1)GL-Gate Low | (1) GL-下桥门极 |
| (2)EL-Emitter Low | (2) EL-下桥发射极 |
| (3)N-Negative Power | (3) N-负电极 |
| (4)P-Positive Power | (4) P-正电极 |
| (5)T1-NTC | (5) T1-热敏电阻 |
| (6)T2-NTC | (6) T2-热敏电阻 |
| (7)GH-Gate High | (7) GH-上桥门极 |
| (8)EH-Emitter High | (8) EH-上桥发射极 |
| (9)CH-Collector High | (9) CH-上桥集电极 |
| (10)/(11) AC Output | (10)/(11)交流输出端 |

Package outlines/封装尺寸

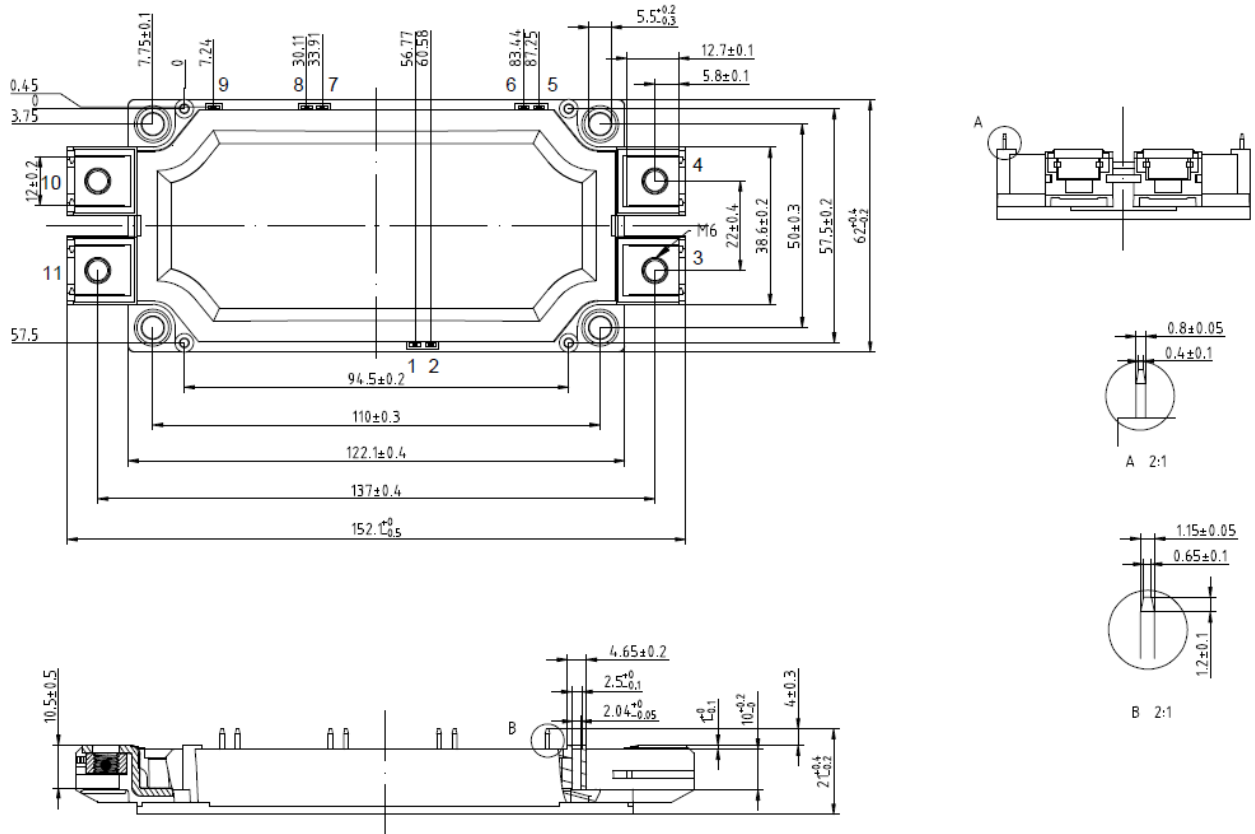



□ Attention

1. When installing the module, please wear an electrostatic bracelet to prevent the gate breakdown and the imbalance power may damage the internal chip, even to damage the module.

当您安装模块时,请佩戴静电手环防止栅极被击穿,静电可能会破坏芯片,甚至损坏模块。

2. This is an electrostatic sensitive device, please observe the international standard IEC 60747-1, chap. IX.

这是静电敏感器件,请遵循国际标准 IEC 60747-1, chap. IX。

Restrictions on Product Use

产品应用的限制

- The information contained herein is subject to change without notice.

此处包含的信息如有变更,不另通知。

- BYD Microelectronics Co., Ltd. (short for BME) exerts the greatest possible effort to ensure high quality and reliability. Nevertheless, semiconductor devices in general can malfunction or fail due to their inherent electrical sensitivity and vulnerability to physical stress. It is the responsibility of the buyer, when utilizing BME products, to comply with the standards of safety in making a safe design for the entire system, including redundancy, fire-prevention measures, and malfunction prevention, to prevent any accidents, fires, or community damage that may ensue. In developing your designs, please ensure that BME products are used within specified operating ranges as set forth in the most recent BME products specifications.

比亚迪微电子有限公司(简称 BME)致力于产品的高性能和高可靠性。然而,因为半导体器件固有的电敏感和较弱的抗物理压力能力,模块容易因此导致失效。当用户购买 BME 的产品时,用户有责任按照安全标准来为整个系统做出安全的设计,包括冗余度、防火、失效预防、来预防任何可能发生的事故、火灾或者可能引起的社区危害。请改善您的设计,确保 BME 的产品在额定范围内使用并参考最新的 BME 产品规格书。

- The BME products listed in this document are intended for usage in general electronics applications (personal equipment, measuring equipment, industrial robotics, transportation instruments, domestic appliances, etc. These BME products are neither intended nor warranted for usage in equipment that requires extraordinarily high quality and/or reliability or a malfunction or failure of which may cause loss of human life or bodily injury (“Unintended Usage”). Unintended Usage include atomic energy control instruments, airplane or spaceship instruments, traffic signal instruments, combustion control instruments, medical instruments, all types of safety devices, etc.. Unintended Usage of BME products listed in this document shall be made at the customer’s own risk.

目录中列出的 BME 产品是用于通用电子装置(个人装置、测量装置、工业机器人、运输装置、家用电器等等)这些 BME 的产品既不是用于超高质量要求,也不是用于失效后会危害人身安全的场合。比如原子能控制装置、飞机或航空器装置、交通信号装置、燃烧控制装置、医疗装置、所有类型的安全设备等等,用在这些不合适的场合会导致用户自己的风险。